



**PUBLISHED TO RECORD
THE UPS AND DOWNS
OF THE
KANSAS SOARING ASSOCIATION**

September 2012

Editor: Tony Condon

PRESIDENT – ANDREW PETERS (2011-2012)

SECRETARY/TREASURER – NEALE EYLER (2011-2012)

VICE PRESIDENT EAST – BOB BLANTON (2011-2012)

VICE PRESIDENT WEST – BOB HALL (2011-2012)

TOW PLANE MANAGER – STEVE LEONARD (2011-2012)

DIRECTORS:

RAY GIRARDO (PAST PRESIDENT)

DAVE STANKO (2011-2012)

K.C. ALEXANDER (2012-2013)

SUMMER GAJEWSKI (2011-2012)

KEITH SMITH (2012-2013)

KSA Elections

Andrew Peters

October is the month we elect Officers and Board of Directors for KSA. This year we have several positions to fill, so now is your chance to nominate yourself or someone (please verify with them first) to give a little back to the club. All positions are serve a two year term.

Officers:

President

VP East

VP West

Secretary/Treasurer

Tow Plane Manager

At Large BOD - 2

Please send nominations to **Leah Condon** at canoecox@gmail.com, 316-249-3535, or 911 N Gilman Wichita KS, 67203 along with a short introduction and what the club means to you. Deadline is September 30th. Instructions for elections, as well as all the nominees, will appear in the October *Variometer*.

Notes from the President

Soaring folk are just good people. How else do you explain it when people dig deep into their pockets and contribute \$4000 to a project like resurfacing a runway. Not only that, but they also come out on weekend mornings to do some difficult manual labor to get the surface ready for the work. All because they love the sport, and want to preserve access to practice the art of soaring. Thank you!

Its not too late. You can still send in a check to **Neale Eyer**. PCI will be starting the work on September 17th, and we should be able to operate on it by Saturday the 22nd.

I am excited to begin to see some changes around Sunflower. The runway will be the most noticeable, but not the only one. There are lots of new members joining the club - so say hello to a new face. There are lots of new glider pilots - **Gavin Smith, Bob Hinson, Matt Gonitske**. There are new gliders (**Tony's** Cirrus, **Steve's** ASW-12).

As the season winds down, there are still lots of reasons to come up and fly. There are two more WWC contest tasks left. Take another look at the traveling trophies and see if you can make a qualifying flight. There's one last cookout in September. The fall can offer some excellent soaring opportunities - so stop making excuses!

Looking ahead, we will have elections in October, when we resume meetings at NIAR. November and December meeting programs are being planned. And our banquet in January.

Fly safe, Fly far, and Fly Fast!

Andrew

KSA CALENDAR

2012

September 8th - KSA Meeting, Cookout at Sunflower

September 8th - 9th - WWC: Lap Race

September 23rd - 29th - US National Aerobatic Contest, Denison, TX

September 27th - 30th - Vintage Rally - Wichita Gliderport, Wichita, KS

October 13th: KSA Meeting at NIAR - 7:30 PM - KSA Elections and World Gliding Championships Review

October 27th - 28th - WWC: Last Man Down

November 10th: KSA Meeting at NIAR - 7:30 PM - Spins, Acro, etc.

December 8th: KSA Meeting at NIAR - 7:30 PM

2013

January 12th - KSA Awards Banquet

February 9th - KSA Meeting at NIAR

March 9th - KSA Meeting at NIAR

April 13th - KSA Meeting at NIAR - Spring Safety Meeting

June 8th-15th - Region 9 Contest - Moriarty, NM

Sunflower Seeds

August 4th: **Scott Dimick** reports: No one showed up to fly. Weather was overcast and a little windy. Gusts over 30 were forecast for mid afternoon but we didn't see them at 2:00. No evidence of lift. Not the best for soaring but it was flyable. No instructor was listed on online schedule. **Brian Bird** showed up to instruct, but no students.

August 5th: **Jerry Boone** (line duty), **Bob Hall** (tow), **Brian Bird** (instructor). **Don Jones**, **Gavin Smith**, and **Bob Hinson** flew the 2-33 and everyone got an hour of time in. **Jerry** flew with **Luke Marquardt**, launching at 5:15pm and flew until 6:30pm. **Brian** gave some instruction and flew 3 flights in the Grob with friends he invited. Altitudes of 5000 – 6500 were made in the blue with light Cirrus overcast. **Jerry** and **Matt Boone** built/ tested a new dolly for the Grob (picture attached). **Jerry** took advantage of the east crosswind to get the Gator out and sweep lots of rock/asphalt type debris from the active portion of the runway.

August 11th: **Gavin Smith** completed his checkride with DPE **Charles Pate** in the WSA 2-33. Towing was **Bob Hall**, ground crew was **Bob Blanton** and **Keith Smith**. Also present were **Andrew Peters**, **Dennis Brown**, **June Blanton**, **Bob Hinson**, **Brian Bird**, and probably others. Skies were generally overcast. **Bob** and **Mike Logback** did three flights each with **Andrew** to prep for their upcoming checkrides. Jacob Frye came out from El Dorado to visit. 12 stayed for the cookout and **Henry Peters** attended his first official KSA event.



Gavin Smith, on the right, Private Pilot - Glider

he is in town on business with Cessna. We assembled and worked on the airbrake rigging on Kate the Std. Cirrus and then the work party broke up.

August 12th: **Mike Logback** towed. **Jerry Boone** flew K7 the Zuni and **Bob Holliday** flew his Ventus (OO). They both made flights for the Weekend Warrior contest. **Bob Hinson** and **David Kennedy** were ground crew. A few pilots from Lithuania visited on their off day from training at Flight Safety in Wichita and one of them took a ride in the Grob with **Jerry**, landing around 6:30. Altitudes achieved were around 7000 feet.

August 18th: **Bob Hinson**, **Charles Pate**, **Andrew Peters**, **Tony Condon**, & Lynn Juby met around 9 AM to conduct **Bob's** Private checkride, which he passed! **Bob Hall** towed. **Andrew** & **Tony** experimented with some weed wacking on the runway before the flying began. Some rain fell right after the checkride then blue skies. **Dennis Brown** showed up as well as **Jeff Beam** but no flying took place. Chris from Holland showed up to visit,

August 19th: **Tony Condon**, **Bob Hall**, **Bob Hinson**, and **Dennis Brown** met around 8 AM. **Mike Davis** was the first student to fly with **Tony**, with **Bob Hall** towing. **Don Jones**, **David Kennedy**, and **Jared Bixenman** followed, with **Jared** climbing to just over 5000 feet in the blue around noon. **Matt Gonitzke** then took over the 2-33 to give a few rides to some friends. **Jack Seltman** showed up for regular tow duty and **John Peters** ran the line with help from others. **Tony** flew with Chris from Holland in the Grob. **Jerry Boone** then took the Grob up to give a friend a ride and they flew to McPherson and back! **Dave Woody**, **Sue McNay**, and **Bob Park** were present. **Bob Hinson** gave Lynn Juby a ride in the 2-33. **John Wells** flew KJ, **Dennis** gave a ride in the 2-33 and then flew LY, and **Lauren Rezac** flew YA. **Matt** flew with **Shea Zuckerman** in the 2-22 and they both also flew in the 2-33. **Tony** launched in Kate at about 3 PM and flew a 130 mile triangle. **Dennis** was last to land, after 6 PM. Altitudes of around 9000 feet with lift up to 7 knots was reported. Busy day!

August 26th: **Jerry Martin**, **Harry Clayton**, & **Sue Erlenwein** ran the line. Start was delayed waiting for morning clouds to lift. **Rafael Soldan** towed. **Bob Hinson** gave a few rides in the 2-33 and **Dennis Brown** flew LY for about 2 hrs. **Bob Park**, **Richard Kirkland**, and **John Wells** were also around.

From the Editor

Well it's been a great season so far and it isn't over yet! Many of us have had some great experiences, whether they be first solos, checkrides, or personal best soaring flights. Now is the time to put those experiences down in words and send them (with pictures!) in so that we have stories to get us through the Winter! Thanks to Hank Claybourn from Oklahoma City I have on loan a bunch of KSA Newsletters starting when the club was founded. I'll be working on scanning these in and probably including some throwback articles in future editions. Something to look forward to!

New Glider

Word is that **Mike Logback** bought a Duster in Michigan. Looking forward to seeing it at Sunflower!

Correction

Neal Pfeiffer's Ka-2b did NOT win the "Best Restoration" award at IVSM, it won the "Best Overall Sailplane"
Congrats **Neal!!!**

Weekend Warrior August

August Results are as follows:

Pilot	Glider	Miles	Handicap Miles	Points
Bob Holliday	Ventus 2	80.48	70.9	1025
Jerry Boone	Zuni	56.47	53.65	782

Weekend Warrior Cumulative

Cumulative Standings are as follows:

Pilot	Glider	Points
Bob Holliday	Ventus 2, Duster	2643
Steve Leonard	Nimbus 3, Zuni II	2025
Jerry Boone	Zuni	2006
Tony Condon	Cherokee II	1224
Andrew Peters	LS-3	706
Lauren Rezac	ASW-24	632
KC Alexander	PIK-20D	508
Keith Smith	PW-5	153

Member Achievements

Gavin Smith Private Checkride August 11th

John Bird earned the OSTIV Mertens award for the best student presentation that the OSTIV Congress in Uvalde, TX.

Bob Hinson Private Checkride August 18th

Tony Condon earned three State Records for his August 19th flight in Kate the Cirrus

Summer Gajewski passed her Instrument checkride at K-State August 20th

Steve Leonard earned a 750 km Diploma for his Kowbell Flight

Where's Summer?

Just a few days after earning her instrument rating, **Summer Gajewski** shipped out for boot camp for the Air National Guard. Send her a letter, I'll be sending her the *Variometer* until she returns:

AB Gajewski, Summer, M
321 TRS FLT 648 (Dorm B9)
1320 Truemper ST Unit 364061
Lackland AFB, TX 78236-6432

Standard Austria

Matt Gonitzke continues to make good progress on the Standard Austria. **Harry Clayton** has been over to help get the tails covered and as you can see below, the wings are once again covered. Probably by the time you read this he will have begun the process of painting everything. We should be seeing it flying at Sunflower soon! **Matt** will also have it on hand at the Vintage Rally in Wichita the last weekend of September so all the more reason to come to that event.



NOTES ON THE 28th ANNUAL U. S. NATIONAL SOARING CHAMPIONSHIPS

by MARSHALL CLAYBOURN, *Contest Manager*

The 28th Nationals will be held from August 1-10, 1961. The site will be the Wichita Municipal Airport.

Those two statements are the main messages of this article. There are additional items of interest regarding the contest and KSA and a series of these pre-contest notes will attempt to supply operational data, background information on the contest area, and answer as many of the anticipated questions the contestants and crews might have as occur to us.

This year the Championships will be sponsored by the Wichita Chamber of Commerce and will be conducted by the Kansas Soaring Association. KSA is a young organization and not experienced at conducting contests. However, we have already received offers of support from the Tulsa Skyhawks and the Texas Soaring Association. Their offer of support is gratefully acknowledged and it will be utilized. As an additional compensation for our lack of experience we have already started weekly meetings to organize the various committees and to define the objectives of each of them. The next article will contain our organization chart and the names of those assigned to head each group.

The dates of August 1-10, inclusive, means the contest will start on a Tuesday and end on a Thursday, as has been the custom for the past several years. These dates were selected for a variety of reasons with the weather, naturally, being the prime factor. Predicting the wily course of the weather has not been developed to a higher accuracy or more refined art in Kansas than it has in other regions. However, it is likely to be less capricious that time of the year.

The Municipal Airport in Wichita is a self-supporting airport owned by the City of Wichita and operated under the auspices of the Board of Park Commissioners. This \$10 million facility was opened in 1954. It is a beautiful airport, located 6½ miles west-southwest of downtown Wichita, built from scratch after the city's original airport became an Air

Force facility as well as the home nest of Boeing B-47's and B-52's.

The aviation committee of the Wichita Chamber of Commerce, under the leadership of Mr. Al Wilson of Yingling Aircraft, has worked diligently with KSA in securing permission from the Board of Park Commissioners to conduct the contest on this facility. Complete operational details, suitable photographs and maps of the site will be prepared for publication as soon as possible. The Competition Rules should be ready for publication in March.

The contest is already destined to be a battle of the champions. KSA's own Harland Ross, holder of U.S. Diamond C No. 14, was the first to state his intention of competing. The first out-of-state competitor to announce his plan to participate was "Redoubtable Richard," Dick Johnson that is, five time winner to the U.S. Championship and famed for his 535 mile world distance record flight. The latter flight, incidentally, terminated some 80 miles north of the site of this year's contest. There is another announced competitor who would cause a big stir even if he hadn't won the Nationals on two previous occasions. He is Dick Schreder who expects to be competing with his new HP-10. The competition looks like it'll be hot and heavy.

If you're the type that likes to start looking the situation over early, consult the Wichita and Salina Sectional charts (and the Lincoln and Sioux City for the really optimistic) or WAC's No. 360 (Kansas River) and No. 307 (Platte River).

As mentioned previously, an attempt will be made to provide as much pre-contest information as is possible to facilitate planning by pilots expecting to compete. However, should anyone have an urgent problem regarding the contest with which we may be of assistance, do not hesitate to communicate. Pre-contest mail should be addressed to: 8034 Levitt, Wichita 7, Kansas. The phone number is MU 4-1585.

Weekend Warrior Contest

by Andrew Peters

For complete Weekend Warrior rules see the April 2012 *Variometer*. Here is the description for the September task, Lap Race!

September 8-9th – WSA Triangle Lap Race

The lap race is a speed task around the WSA triangle is defined by the Castleton, Haven, and HUT VOR turnpoints. The WSA triangle was intended to help club members develop XC skills while staying within gliding distance of Sunflower. This task is similar to the Assigned Speed Task used in competition.

For the WWC, here is the Lap Race task:

- Start Point: Overhead Sunflower, from the east.
- Maximum Start Height: 3500' AGL x your Handicap (e.g. 1582' + 3500' x 0.915 = 4785' MSL)
- Must fly to the turn points defining the WSA Triangle, in the order given below
 - North Flow (TO/L Rwy 35): Sunflower – Castleton – Haven – HUT VOR – Sunflower
Note: this sets you up for Right Hand Traffic to land on Runway 35.
 - South Flow (TO/L Rwy 17): Sunflower – HUT VOR – Haven – Castleton – Sunflower
- Competitors may fly multiple laps around the course. However, to have a valid speed lap, you must start below the maximum start height.
- No points will be scored for partial laps.
- Photos are not required, if you don't have a GPS logger. You will need to verify start times with an observer on the ground.
- Treat the turnpoints like pylons, you must go around the outside of the turnpoints (around the pylon.)

Scoring:

1st lap = 500 pts

Fastest Handicapped speed = 500 pts

Fastest Raw Speed = 100 pts

Additional Laps = 100 pts each (up to maximum of 200 pts.)

Turn point files can be found at <http://soaringweb.org/TP/NA.html#US> for Hutchinson, KS.

Task Explanation

The start will be over Sunflower from the east side of the field (plan to cross the runway over the sunshade on your way to the first turn.) Note your time crossing the start line. Also, remember that the maximum start height is 1582 + 3500 x your handicap. You need to cross the line below this altitude. Call in your start time on 123.5, "3T 1540." If you don't have a GPS, ask an observer on the ground to watch your start. Ask to borrow a hand held radio.

Fly around the first turn point (either Castleton or HUT VOR), then proceed to the next turn point (Haven), then to the last turn point (either HUT VOR or Castleton) and return to Sunflower. Cross the runway from the west at least 500' AGL (2082' MSL), at the sunshade and announce your finish time. You can land, or run the course again. If landing to the north (runway 35), plan on right traffic patterns.

Remember to fly around the turnpoints, as if they were pylons. The HUT VOR is the white traffic cone just west of Mills field (grass North/South runway.) The Haven turnpoint is the center of town, at the intersection of Main street and Kansas Avenue. Castleton's turnpoint is south of Castleton Road, at Main Street and Front Street. Check them out on Google Maps .

Plan on making a radio call after passing the last turn point, "3T HUT VOR inbound for a speed finish."

If anyone observes unsafe or low finishes, disqualification or penalties may result.

KSA at the World Championships

KSA members attending the World Championships at Uvalde included **Matt Gonitzke, Tony Condon, Steve Leonard, John Bird, Lauren Rezac, Bob Holliday, Neal Pfeiffer, Jerry Boone, & Matt Boone**. **Steve** attended the entire contest, crewing for his brother Dave, who flew his ASW-27B in 15 Meter. **Matt & Tony** attended the first week of the contest, helping Dave as well as any other US Team members needing a hand. **Lauren** was there for the first 3 or 4 days, also helping out. **Bob, Jerry, Matt, & Neal** flew down in **Bob's** 172 for 2 days. **John** was there for about $\frac{2}{3}$ of the contest and presented his paper to the OSTIV congress during the contest. Highlights of the contest was observing the launches and landings. About the only thing more impressive than seeing 100 glider launch in an hour is seeing 100 land in an hour. 15 gliders in the pattern is quite a sight. The Concordia, Dick Butler's Open Class glider, was an attraction; **Matt & Tony** enjoyed getting to help his crew get it ready to launch on a few of the mornings. It holds a LOT of water!

The contest went the full scheduled 13 days of flying and enough miles were flown to go to the moon and back. The winners scores were the highest ever achieved at a Worlds Championships. Uvalde 2012 will no doubt go down in history and we were all glad to have witnessed it. Here are some pictures, look forward to more at the October KSA meeting!



Steve, Lauren, Matt, Dave, Tony



Matt & Tony water up Concordia



Concordia takes off

September/October 2012 Duty Schedule

For complete schedule, see May 2012 *Variometer* and <http://my.calendars.net/ksa>
 Sub List: Rich Stone (LLM) 612-2008, Frank O'Donnell (CFIG, Tow Pilot) 316-788-3224

Sat Sep 1	Mike Westemier 729-2551	Jared Bixenman 785-443-2457 Doug Wilson 733-6484	Brian Bird 636-4218
Sun Sep 2	Mike Logback 620-241-8486	Dave Woody 682-1895 David Kennedy 841-2912	
<u>Mon Sep 3</u> Labor Day	Lauren Rezac 619-3207	Richard Boone 351-7133	
Sat Sep 8 Cookout	Bernie Mohr 733-4524	David Wilkus 788-0932 Kevin Ganoung 785-536-4540	Lauren Rezac 619-3207
Sun Sep 9		Jared Bixenman 785-443-2457 Mike Davis 772-8535	
Sat Sep 15	Jack Seltman 636-4218	Ron Blum 295-7812 Steve Leonard 249-7248	Mike Westemier 729-2551
Sun Sep 16	Tony Condon 515-291-0089	Leah Condon 249-3535 Matt Gonitzke 815-980-6944	
Sat Sep 22	KC Alexander 943-7641	John Baldessari Bob Hinson 841-5561	Andrew Peters 636-4218
Sun Sep 23	KC Alexander 943-7641	David Kennedy 841-2912 Scott Dimmick 733-5678	
Sat Sep 29	Chris Swan 513-410-2418	Jeff Beam 620-441-8116 Jared Bixenman 785-443-2457	Andrew Peters 636-4218
Sun Sep 30	Mark Ross 636-4218	Ray Girardo 942-0638 Mike Logback 620-241-8486	
Sat Oct 6	Bob Holliday 641-6178	Doug Wilson 733-5537 Jared Bixenman 785-443-2457	Brian Bird 636-4218
Sun Oct 7	Bob Hall 636-4218	Keith Smith 785-643-6817 Kevin Ganoung 785-536-4540	
Sat Oct 13		David Wilkus 788-0932 Richard Boone 351-7133	Mike Westemier 729-2551
Sun Oct 14	Jack Seltman 636-4218	Harry Clayton 644-9117 Jerry Boone 620-662-5330	
Sat Oct 20	Rafael Soldan 706-255-9909	Bob Blanton 683-9759 Robbie Grabendike 680-0622	
Sun Oct 21	Chris Swan 513-410-2418	Leah Condon 249-3535 Matt Gonitzke 815-980-6944	Tony Condon 515-291-0089
Sat Oct 27	Bob Holliday 641-6178	Steve Leonard 249-7248 Kevin Ganoung 785-536-4540	Brian Bird 636-4218
Sun Oct 28		Neale Eyler 729-0659 Mike Logback 620-241-8486	



We are very proud and excited to announce our first Twin.

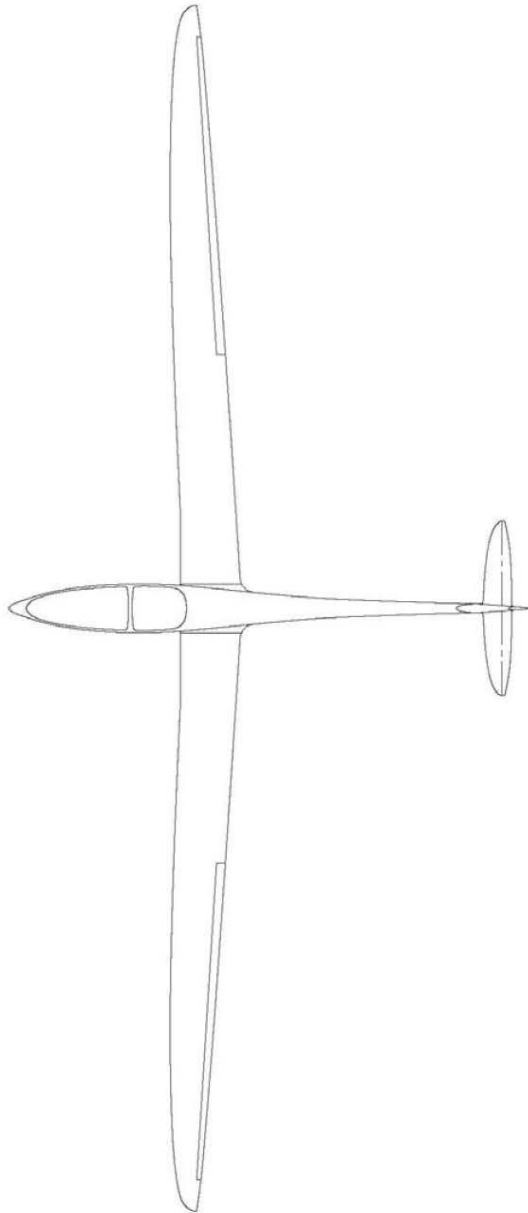

Span	20m (65.62 FT)
Wing Area	15.28 m ² (164.5 FT ²)
Aspect Ratio	26.18
Max Weight	600 kg (1320 LBS)
Max Wing Loading	39 kg/m ² (8.0 LBS/FT ²)
Empty Weight	360 kg (800 LBS)
Maneuver Limits	+6.5 / -4 g's
Seat Limits	140 to 240 LBS



BRS capable
LSA certified

Is it a high performance twin that is a tough trainer or is it a tough trainer that is a high performance twin?
It is both. It is the new standard.

Interested parties should contact
Windward Performance for ordering
details.



We are very proud and excited to announce a special, limited, program.

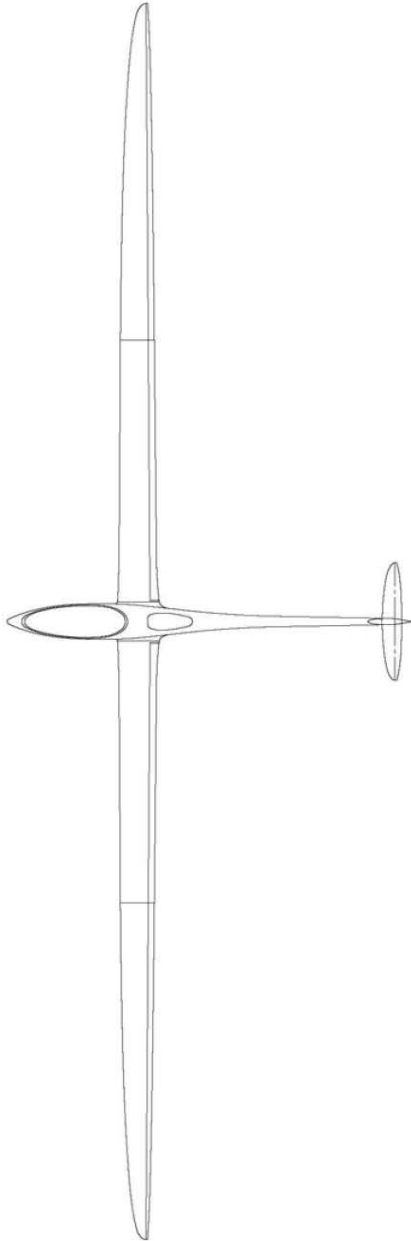

Span	22m (72.16 FT)
Wing Area	12.06 m ² (129.81 FT ²)
Aspect Ratio	40.11
Max Weight	850 kg (1874 LBS)
Max Wing Loading	70.4 kg/m ² (14.4 LBS/FT ²)

Powerplant	TJ-100E3
Max Thrust	240 LBS

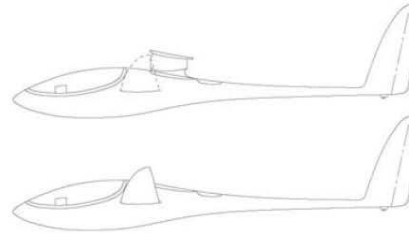

BRS capable

Interested parties should contact
Windward Performance for ordering
details.

**The 7th Great Plains
Vintage/Classic Sailplane Regatta**
September 27-30, 2012
With cooperation from
**The Vintage Sailplane Association &
The Kansas Soaring Association**
at
Wichita Gliderport (37.765 N, 97.180 W)
Just NE of Wichita, Kansas

*Come join the fun, show off & fly your vintage/
Classic glider.
Limited hangar space available, call!*

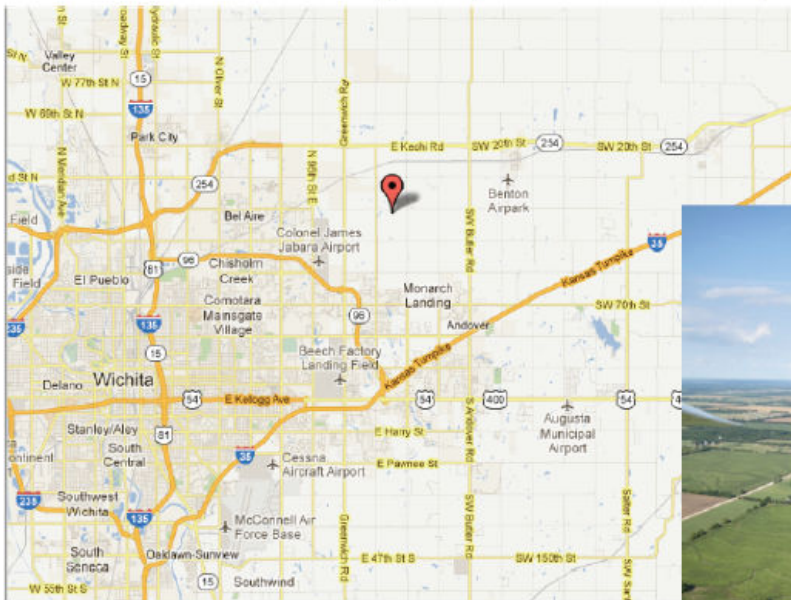

**Contact: Neal Pfeiffer (316) 641-9928 nealpfeiffer@sbcglobal.net
or Tony Condon (515) 291-0089 abcondon@gmail.com
or Harry Clayton (316) 644-9117 hclayton@pixius.net**

Wichita Gliderport - 37.765 N, 97.180 W
13501 E 45th St N, 1-1/2 miles east of Greenwich on 45th St N

Wichita Gliderport

- *2600' & 4000' grass*
- *2000' tows are \$20*
- *Limited hangar space*
- *Some camping at field*
- *Close to motels*
- *Close to restaurants*
- *Schweizer 2-33 two-place glider for rent*



*Lunch options available at airport
Cookouts or local restaurants for dinner*

*Informal Soaring Seminar on Saturday Morning
Starting at 10:00 AM*

*Tell us you're coming & let us know
if you're bringing a glider!!!
If you can't bring a ship,
just come and have fun.*

*Motels: Search maps.google.com for 'Motels East Wichita, KS'
start along North Greenwich Road or Webb Road down to US 54*

*Wichita Gliderport - 37.765 N, 97.180 W
13501 E 45th St N, 1-1/2 miles east of Greenwich on 45th St N*

<p style="text-align: center;">KSA TOWCARD</p> <p>TOW NUMBER START TACH TIME</p> <p>_____</p> <p>TOW PILOT _____</p>	<p style="text-align: center;">KSA TOWCARD</p> <p>TOW NUMBER START TACH TIME</p> <p>_____</p> <p>TOW PILOT _____</p>
<p>PILOT _____</p> <p>ADDRESS _____</p> <p>_____</p> <p>SAILPLANE _____</p> <p>TOW HEIGHT _____</p> <p>TOW SPEED (MPH) _____</p> <p>DATE _____</p>	<p>PILOT _____</p> <p>ADDRESS _____</p> <p>_____</p> <p>SAILPLANE _____</p> <p>TOW HEIGHT _____</p> <p>TOW SPEED (MPH) _____</p> <p>DATE _____</p>
<p style="text-align: center;">KSA TOWCARD</p> <p>TOW NUMBER START TACH TIME</p> <p>_____</p> <p>TOW PILOT _____</p>	<p style="text-align: center;">KSA TOWCARD</p> <p>TOW NUMBER START TACH TIME</p> <p>_____</p> <p>TOW PILOT _____</p>
<p>PILOT _____</p> <p>ADDRESS _____</p> <p>_____</p> <p>SAILPLANE _____</p> <p>TOW HEIGHT _____</p> <p>TOW SPEED (MPH) _____</p> <p>DATE _____</p>	<p>PILOT _____</p> <p>ADDRESS _____</p> <p>_____</p> <p>SAILPLANE _____</p> <p>TOW HEIGHT _____</p> <p>TOW SPEED (MPH) _____</p> <p>DATE _____</p>

KSA VARIOMETER

911 N Gilman

Wichita, KS 67203

abcondon@gmail.com

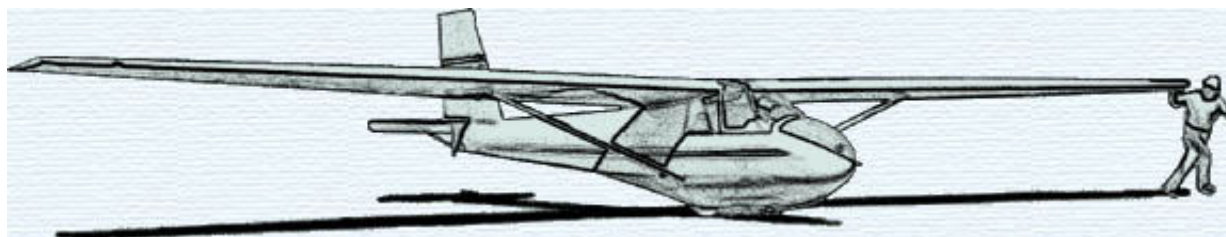

MONTHLY KSA MEETING

Cookout at Sunflower

Saturday September 8th, 2012

Grill lights by 5:30 PM

Meat provided by KSA, bring a side dish to share!